

Crane lifting eye optional  
Article number: 910022005

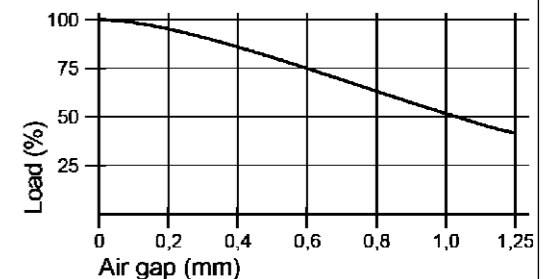
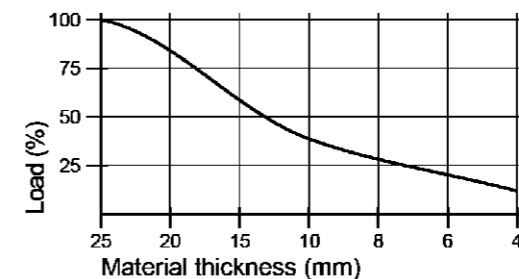
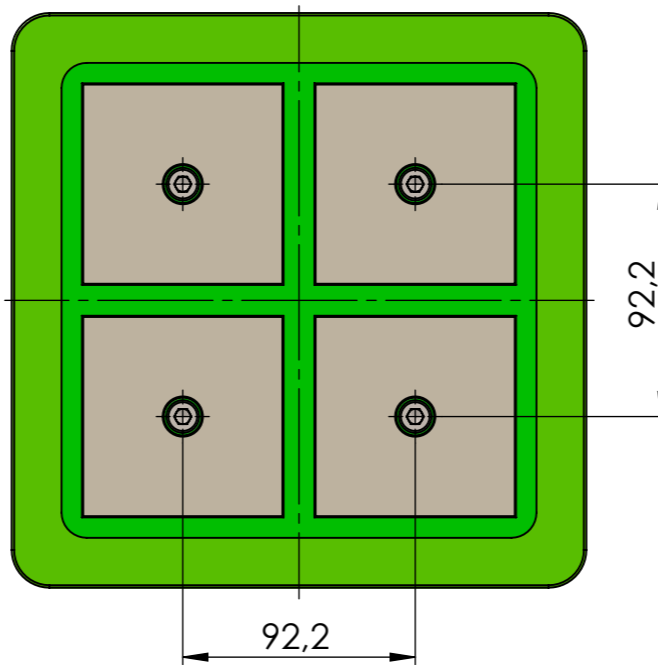
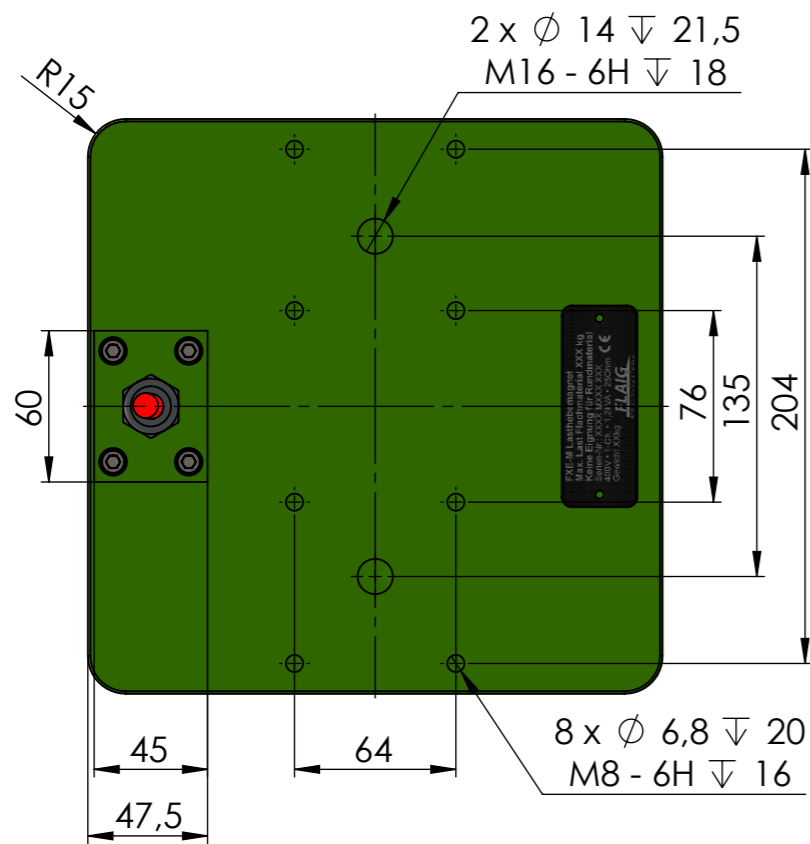
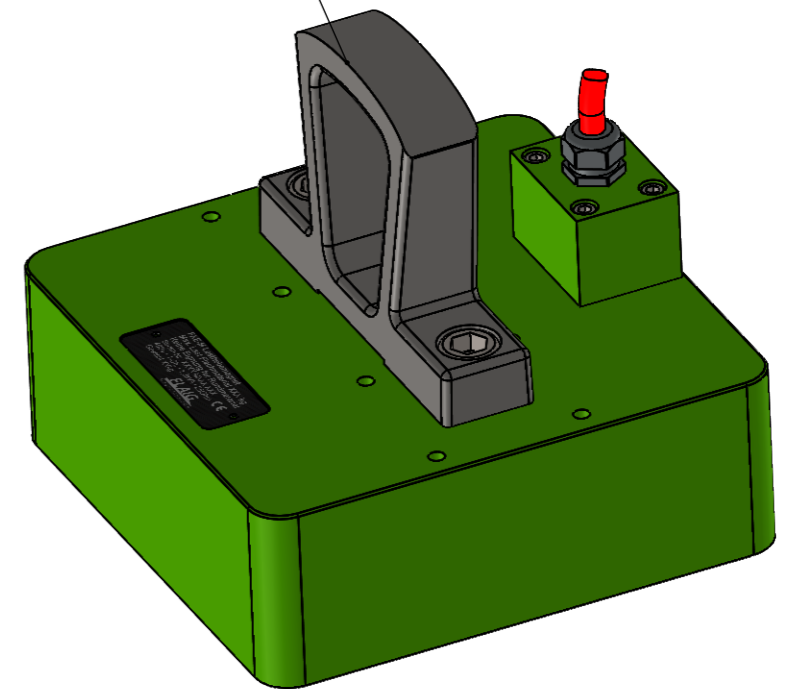

Specification FXE-M 1000-80		Schutzvermerk nach DIN ISO 16016 beachten! Nachdruck nur mit unserer Genehmigung! All rights reserved according to DIN ISO 16016! Reprint with our permission only!		tolerance		material:		weight: 31.40		
Nominative Force: 36kN	lifting capacity EN 13155/WLL		ISO 7168 M	drawing no.: <b>0013015</b>						
Materialthickness >25mm (100%)	1000kg		date	name	description: <b>FXE M 1000-80</b>					
4,3kVA			drawn 16.02.2021	MF	part no.: <b>10611002</b>					
U: 380-480V Pulse	Protection Type IP 65		edit 25.05.2022		sheet 1 / 1					
R: 6,4Ω	Protection category SK I	appr. 25.05.2022	TW	A3						
		rev.	change	date	name	 www.flraig-te.de		scale: 1:3		
						Status: Freigegeben				